

VLT® Soft Start Controller MCD 100

MCD 100 is a cost effective and extremely compact soft starter for AC motors up to 15 HP. Due to a unique semiconductor design MCD 100 is a true “fit and forget” product. Selection can be made on the basis of the motor power—exactly as with traditional contactors.



The new range features three different products, MCD 100-001 (2 HP), MCD 100-107 (10 HP), and MCD 100-011 (15 HP). In fact the MCD 100-001 is **the world’s smallest soft starter** rated up to 2 HP. All sizes are rated for line voltages up to 600 VAC.

MCD 100 products provide timed voltage ramp up and down. Ramp time can be individually adjusted with rotary switches from 0.4 to 10 seconds. The start torque can be adjusted from 0 to 85% of the direct on-line torque.

Application

MCD 100 is an ideal alternative when starting smaller AC motors direct on-line or with a star-delta starter. The typical applications would be soft start / stop of conveyor systems, pumps, and soft start of smaller compressors, for example scroll or reciprocating compressors in air-conditioning units. MCD 100 products can be installed side by side and with or without a line contactor. Motor protection must be installed separately. Short circuit protection can be achieved by the use of fuses or a circuit breaker.

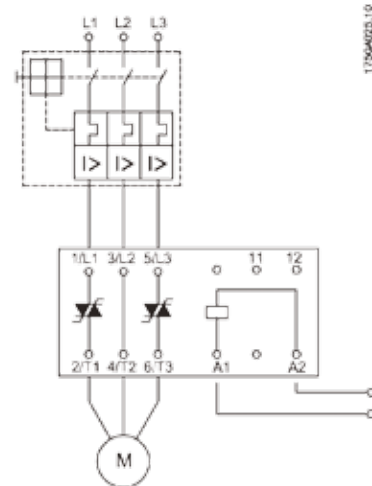

Application example of a motor controlled by MCD 100 and protected by a circuit breaker.

Benefits with MCD 100 over traditional small soft starters

- A robust semiconductor design – selection can be based on motor power which ensures easy selection. It can be used for an almost unlimited number of starts per hour without derating.
- A universal control voltage (24-480 VAC / VDC)—simplifies selection and keeps stock at a minimum.
- A “fit and forget” contactor design—simplifies installation and reduces required panel space.
- Digitally controlled rotary switches—secures precise settings and simplifies installation.
- Ratings for heavy duty as standard—simplifies installation and reduces the risk of breakdown.

Perfect

match for:

- Pumps
- Fans
- Compressors
- Mixers
- Conveyors
- and many more

Specification and ordering code numbers

Type	Max Power- Top to Bottom	Max. FLC	Voltage	Code number
MCD 100-001	1 HP	3 A	208 – 240 V	175G4000
MCD 100-001	2 HP	3 A	400 – 415 V	175G4001
MCD 100-001	2 HP	3 A	440 – 480 V	175G4002
MCD 100-001	3 HP	3 A	550 – 600 V	175G4003
MCD 100-007	5 HP	15 A	208 – 240 V	175G4004
MCD 100-007	10 HP	15 A	400 – 480 V	175G4005
MCD 100-007	10 HP	15 A	500 – 600 V	175G4006
MCD 100-011	10 HP	25 A	208 – 240 V	175G4007
MCD 100-011	15 HP	25 A	400 – 480 V	175G4008
MCD 100-011	20 HP	25 A	500 – 600 V	175G4009

Technical data

	MCD 100-001	MCD 100-007	MCD 100-011
Dimensions (width)	.88 inches	1.77 inches	3.54 inches
Load rating (EN 60947-4-2)	3A:5-5:10		25A:8-3:100-3000
Semiconductor protection			
Type 1	25 A gL/gG	50 A gL/gG	80 A gL/gG
Type 2	72 A2s	1800 A2s	6300 A2s
Power loss	Max. 4 W	2 W/A x duty cycle	
Ambient temperature	-5 C to 40 C (above 40 C with derating)		
Approvals	CE, cULus (UL508)		